

Zbigniew Talaśka*

**THE CONSTRUCTION
OF A BREATHING SIMULATOR FOR RESEARCH
OF THE DIVING BREATHING APPARATUS
IN COMPLIANCE
WITH THE PN-EN 250:2014 STANDARD**

ABSTRACT

The article discusses the construction of a breathing simulator used at the Department of Underwater Works Technology of the Polish Naval Academy in Gdynia for the research on an open-circuit air diving apparatus for compliance with the PN-EN 250:2014 standard.

Key words:

air breathing apparatus, hyperbaric breathing simulator.

INTRODUCTION

Introducing new diving equipment constructions to service, as well as verifying their technical and operational properties requires, among other things, bench testing with the use of a breathing simulator, colloquially referred to as artificial lungs. The PN-EN 250:2014-08 standard — Breathing equipment. Open-circuit, air breathing apparatuses with compressed air. Requirements, tests and labelling is one of the documents that provides the base for conformity tests. The purpose of the physical examination is to ensure a minimum level of safe operation of air breathing apparatuses up to maximum depth of 50 m of the water column (0,5 MPa). The

* Polish Naval Academy, Faculty of Mechanical and Electrical Engineering, Department of Underwater Works Technology, Śmidowicza 69 Str., 81-127 Gdynia, Poland; e-mail: z.talaska@amw.gdynia.pl

standard is a substantive basis for a set of laboratory test and operation procedures, which provide grounds for evaluation if the tested breathing equipment (SCUBA) conforms to the parameters presented in it. This means that a given open-circuit air breathing apparatus with compressed air for underwater breathing may be authorised only when its parts meet the requirements defined in the test specification, in the standard or its part. In addition, successful field tests of the complete apparatus must be performed.

Laboratory test with the use of a breathing simulator should be conducted in the following sections of the standard:

- dynamic operation of the apparatus (SCUBA) — general provisions — point 6.7.1;
- operation in cold water — point 6.7.2;
- tank valve — point 6.9;
- the content of carbon dioxide in exhaled air — point 6.10.2.1, which constitutes the subpoint of 6.10.2;
- reserve valve — point 6.11.2;
- other active warning devices (if present) — point 6.11.3;
- resistance to defined temperatures — point 6.12 which includes:
 - a test after being stored in temperature +70°C — point 6.12.1,
 - a test after being stored in temperature –30°C — point 6.12.2.

THE CONSTRUCTION OF A BREATHING SIMULATOR

The station of the breathing simulator built and operated in Department of Underwater Works Technology of the Polish Naval Academy in Gdynia (ZTPP AMW), is composed of the following basic parts:

- a hyperbaric chamber with a lid;
- the system of chamber lid lifting'
- breathing simulator — a respiration pump with drive;
- the system of water temperature control in the chamber;
- navigation and control panel composed of:
 - gas power supply system of the chamber,
 - measuring systems with sensors,
 - computers with software that controls the operations of the decompression chamber and registers measuring parameters during tests in real time.



Fig. 1. Photo shows the test stand of a breathing simulator built at the Department of Underwater Works Technology Polish Naval Academy (Zakład Technologii Parc Podwodnych Akademii Marynarki Wojennej — ZTPP AMW) [from the ZTPP AMW archive]

Hyperbaric chamber with a lid

The basic element of the test stand is a decompression chamber which enables simulation of surrounding conditions at a given depth. It integrates most component parts which cooperate with the chamber into one functioning whole, ensuring the performance of essential measurements of technical and operational parameters of diving equipment in versatile conditions of marine environment.

The interior of the chamber provides conditions for breathing equipment or its selected parts to be placed inside. When necessary, other groups of diving equipment may be placed inside, e.g. housing of an underwater camera.

The hyperbaric chamber has been designed to provide conformity with, among others, the PN-EN 250:2014 standard, especially:

- possibility to achieve relative pressure equal to at least 0,5 MPa, which corresponds to the depth of 50 m H₂O from the surface of water;
- possibility to hold breathing apparatuses of varying size cylinders positioned both horizontally and vertically, with minimum 20 cm of water layer over the tested equipment ensured for the purpose of eliminating surface effects;
- simulation of water temperature changes around the tested equipment, ranging from +4°C to +20°C.

Through its special design, the chamber enables relatively quick closing and opening and provides an easy access to testing space where the studied breathing

apparatuses are placed. The pressure vessel ensures the supply of all necessary systems, including compressed air and water. The systems are connected with the navigation and control stand.

The entrance of the hyperbaric chamber is locked by the flat lid with protruding arms, which are used for lifting it at a desired height. Mechanical and electronic actuators are placed on the surface of the lid. Different diameter holes in the lid provide passages for such elements as the drive of breathing simulator (respiration pump), as well as connections for measuring and control systems equipped with sensors. They ensure a constant and uninterrupted signal output from sensors placed on the tested equipment inside the chamber. Such setup enables the ongoing control of technical and operational parameters of the equipment, as well as the parameters of hyperbaric chamber operations.

Under the lid, a transport basket has been hung on four steel rods where the elements of the tested diving equipment are placed. Onto the rods, sliding lights and overview cameras that cooperate with the system of test monitoring and video recording have been mounted. The position of the basket may be adjusted, and new elements may be added, e.g. testing equipment, depending on the needs.

Figure 2 demonstrates the interior of the decompression chamber and the lid locking system with a clamping ring.

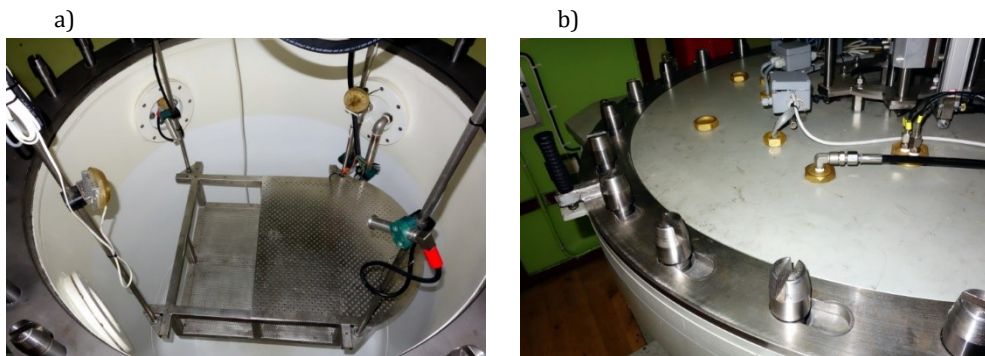

Fig. 2: a) the interior of the decompression chamber; b) the lid locking system with a clamping ring [from the ZTPP AMW archive]

The lid lifting system of the hyperbaric chamber

The total weight of the decompression chamber lid together with the devices, testing equipment and the diving apparatuses placed on and under it, has been estimated to amount to several hundred kilograms. Its mass is justified by a relatively large inside diameter of the vessel and resistance to working pressure that amounts

to 2 MPa. The lid is lifted by means of a specially designed two-column lift equipped with deployable arms with the total load capacity of approx. 4 tonnes. It is a very simple, reliable and inexpensive solution.

The lid lifting and lowering process is controlled by computer software prepared by the ZTPP AMW. It ensures changeable movement dynamics of the lid and leaning control in relation to the placement of the chamber with a high-precision electronic spirit level. This enables an accurate settlement of the lid in the upper ring of the vessel without jamming, with an insignificant difference in distance between the diameters of both elements.

The height at which the lid is lifted enables a free access to the transport basket, in which the tested elements are deployed and connected to the measuring system.

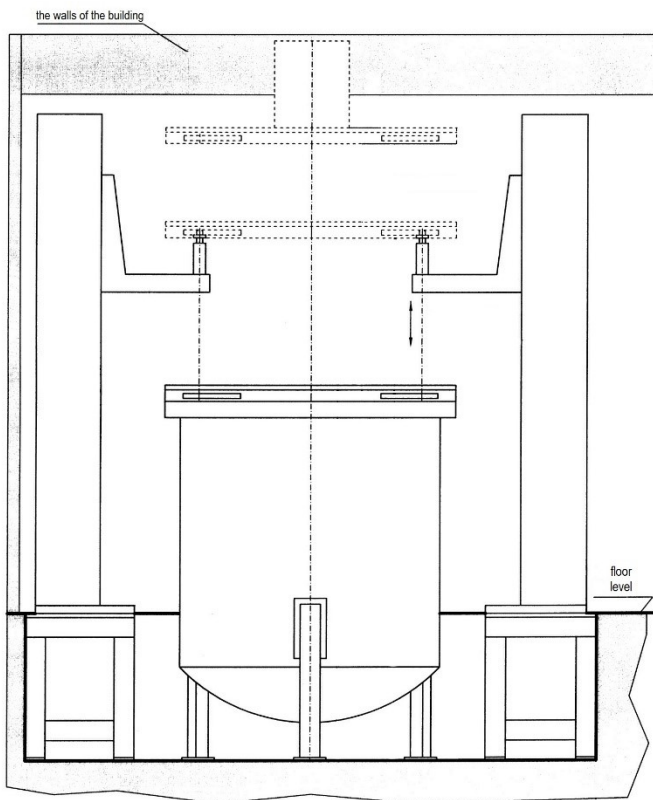

Fig. 3. A diagram demonstrating the installation of the chamber lid lift [own work]

Breathing simulator

The second most important element of the test stand is the breathing simulator. Its most essential function is to imitate human breathing process in a manner

that is as close to the conditions of real breathing as possible. The measurement of the diving gas volume that is pumped through the simulator in combination with the measurement of breathing pressure changes enables the determination of diver's breathing work through a particular demand regulator.

The used simulator is a pressure respiration pump by construction, seated centrally on the lid of the hyperbaric chamber. In terms of functionality it is divided into an outside drive part and respiratory part placed inside the chamber. This solution ensures a tension-free operation of the device without the need to balance the pressure on both sides of the piston. The drive mechanism is a typical, widely-used camshaft system that converts circular motion into the reciprocating motion. The servomotor reducer used ensures the obtainment of a precise number of revolutions controlled by computer software.

In compliance with the PN-EN 250:2014 standard, the breathing simulator should:

- operate under absolute pressure amounting to 6 bar (0,6 MPa);
- ensure that the simulated respiration is sinusoidal, with frequency and amplitude changes not diverging from their set values by more than $\pm 3\%$;
- ensure a minute ventilation for most cases at the level of 62,5 dm³/min (25 cycles/min; 2,5 l/stroke) and the ventilations: 15 dm³/min and 20 dm³/min.

Basic operations of a breathing simulator, on the active side, consist in unilateral suction and then forcing out of the breathing gas through the II degree of the demand regulator combined with the pressure regulator and a cylinder, placed in the water part of the hyperbaric chamber. When the pump drive is started, a difference of pressure is created which has the value of overpressure or negative pressure required for collecting an air dose.

The other, passive side of the piston is connected with the atmosphere of the hyperbaric chamber through the holes in the upper lid. During standstill on both sides of the piston the pressure is equalized.

The piston is driven by a piston rod which runs through a set of seals in the upper lid of the respiration pump and then leads out of the chamber through the central opening in the lid of the hyperbaric chamber. The lower lid of the pump is equipped with an outlet which enables the connection with the demand regulator. The piston stroke is effected upwards from the bottom position and back. The stroke height is set outside the chamber in the drive module. Appropriate settings reflect the ventilation of lungs ranging from 10 to 160 dm³/min.

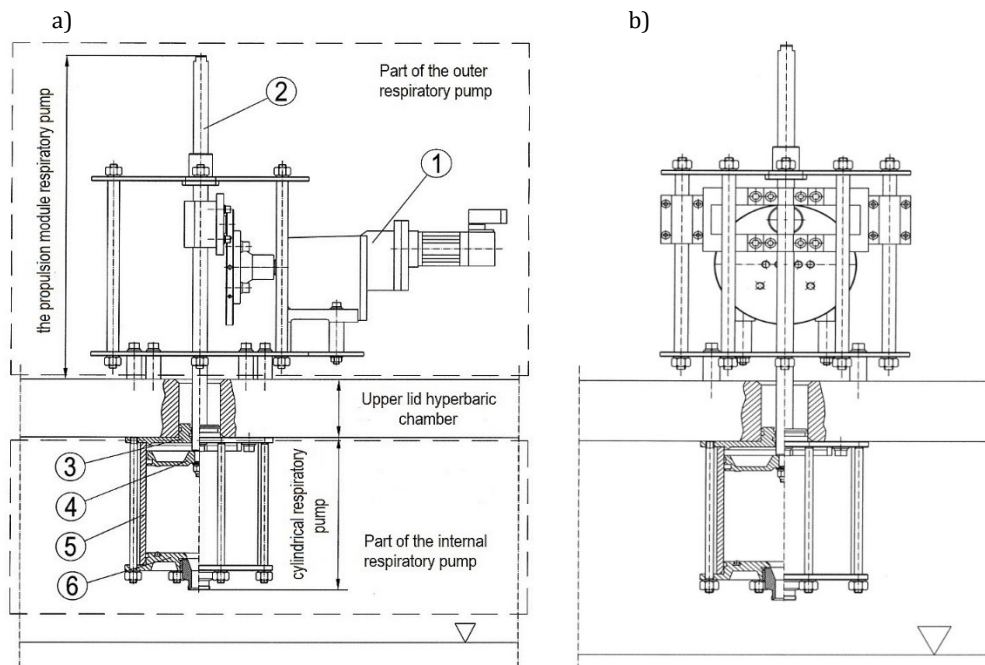

Fig. 4. Functional diagram demonstrating a breathing simulator — respiration pump: a) 1 — servomotor reducer ensures an accurate circular motion, 2 — the piston rod of the pump, 3 — upper lid of the pump, 4 — piston of the pump, 5 — pump cylinder, 6 — bottom lid of the pump [own work]

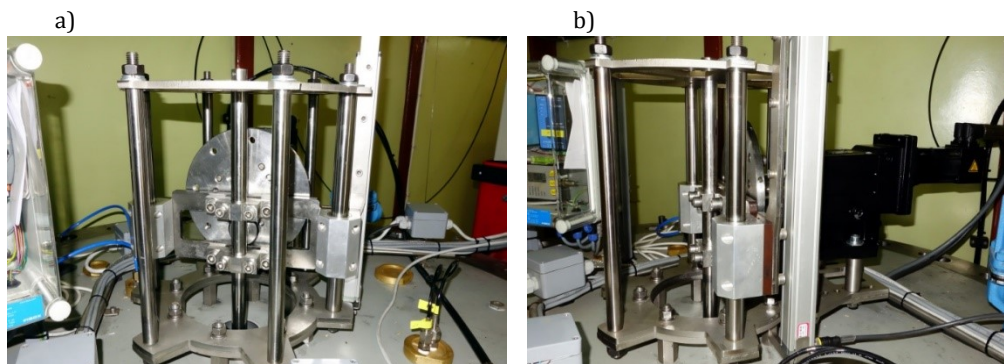

Fig. 5: a), b) breathing simulator installed on the upper lid of the hyperbaric chamber [from the ZTPP AMW archive]

System of water temperature control in the hyperbaric chamber

The range of tests conducted in accordance with point 6.7.2. of the standard includes the testing of the operation of the entire diving apparatus or its selected components intended for the use in water with the temperature no less than +10°C. Therefore,

the ambient temperature of the tested equipment must be $+4^{\circ}\text{-}_2^{\circ}\text{C}$. Diving practice indicates that a series of demand regulators do not meet the conditions of use in lower temperatures of water. Improper selection of diving equipment may lead to a diving accident.

The system of water temperature adjustment used in the breathing simulator has the following features:

- it ensures cooling of approx. 1,3 tonnes of water in less than one hour;
- the process of cooling water is taking place in the indirect system with the radiator placed outside the tank; this ensures a possibility of a better employment of the internal volume of the chamber for testing purposes which is devoid of the heat exchanger with a matching shape;
- the cooling system is equipped with a cooling unit, circulation pump that pumps water through the heat exchanger in a closed-circuit pressure system;
- insulated pipelines of the temperature adjustment system ensure a constant liquid movement in the chamber which maintains the uniformity of temperature in the entire water mass;
- in order to prevent the heat exchange with the exterior of the chamber it has been insulated with a carefully selected coating and covered with sheets of stainless steel;
- maintenance of temperature on a selected level is ensured automatically in the water adjustment system.

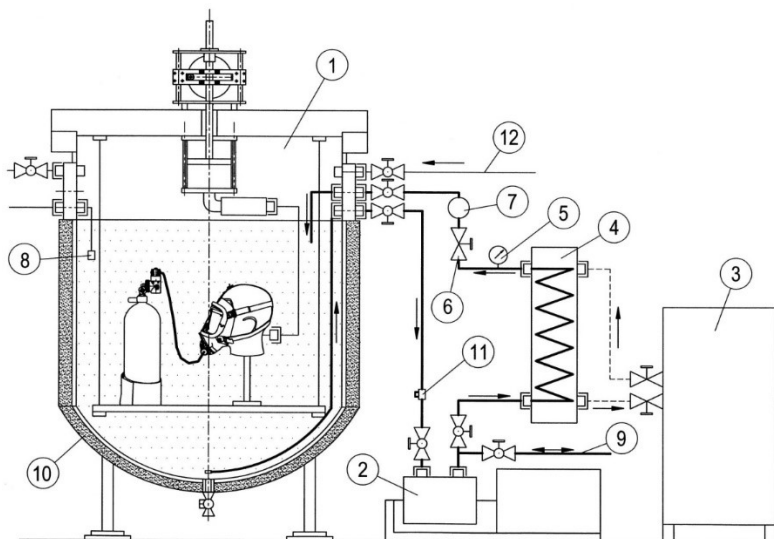

Fig. 6. Conceptual design demonstrating the system of water temperature adjustment in the hyperbaric chamber: 1 — decompression chamber (dry space), 2 — circulation pressure water pump, 3 — cooling unit, 4 — heat exchanger, 5 — indicator of liquid pressure in water circulation, 6 — control valve of water flow in the circulation, 7 — flowmeter, sensor of water temperature in the chamber, 9 — filling and emptying of the hyperbaric chamber with water, 10 — outer thermal insulation of the chamber, 11 — additional connector, 12 — inlet of compressed air to the hyperbaric chamber [own work]

Navigation and control panel of a breathing simulator

The navigation and control panel of a breathing simulator is composed of a set of devices for operating the hyperbaric chamber with the working pressure of 2 MPa. In the panel you can find pressure installations together with a set of valves and measuring tools that enable direct control of the chamber's operation. Pipelines and their connectors have been placed in the rear part of the panel. Additionally, it has been equipped with the electrical installations and three computers used for: controlling the movement of the upper hyperbaric chamber, video recording from the outside overview cameras and setting and recording technical parameters of the tested equipment. Most of the operating and measuring devices have been deployed on the faceplate. Under the faceplate a fixed desktop has been installed for operating the keyboard and making notes during the tests. Some electric and electronic devices have been placed in electrical boxes outside the panel.

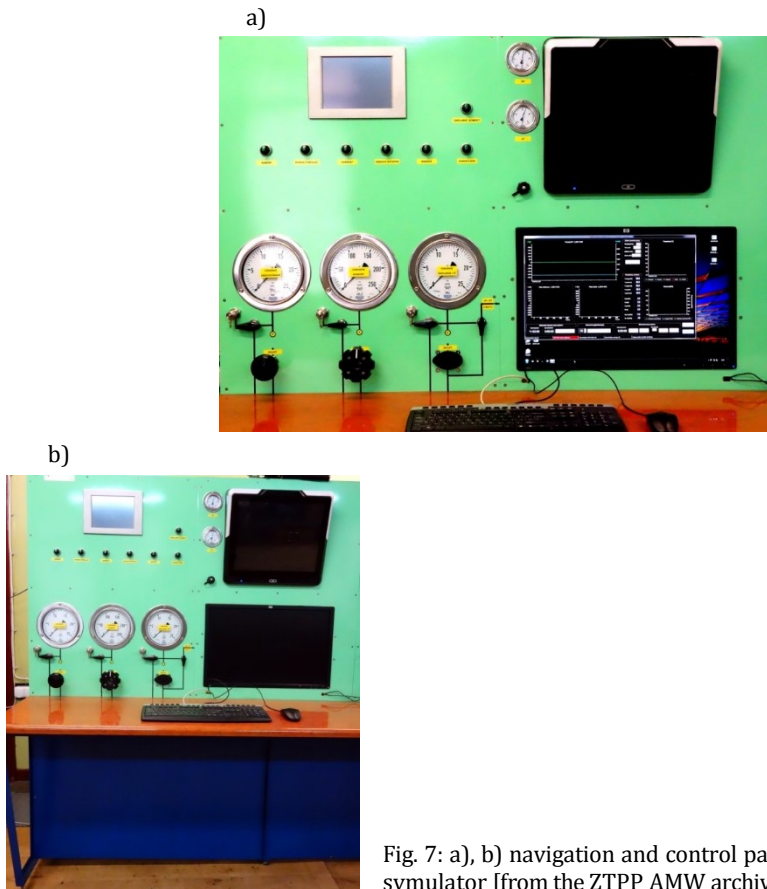

Fig. 7: a), b) navigation and control panel of the breathing simulator [from the ZTPP AMW archive]

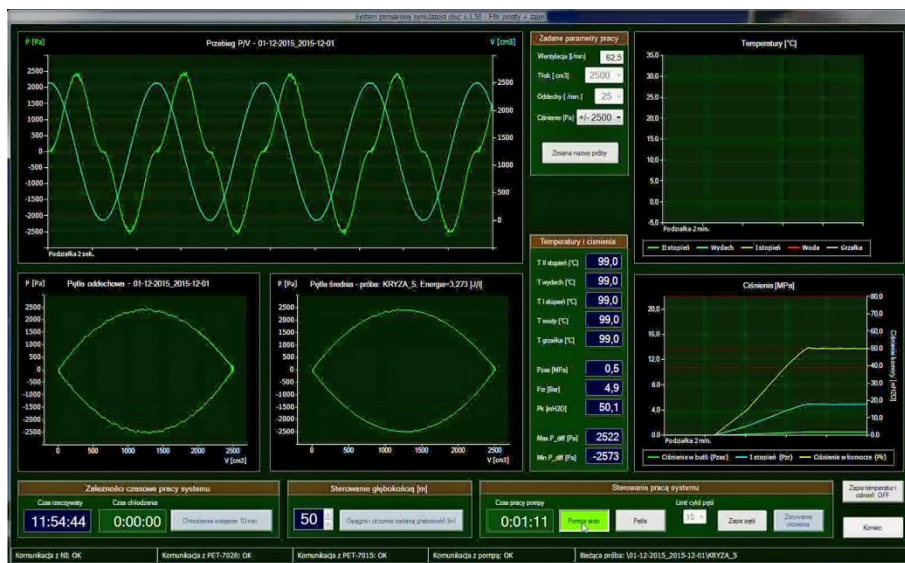

Fig. 8. Interface of the programme for setting and recording measuring parameters during the testing of an air breathing apparatus [PrintScreen: own work]

REFERENCES

- [1] Kłós R., *The new generation of hyperbaric breathing simulator*, Akademia Marynarki Wojennej [Polish Naval Academy, Department of Underwater Works Technology], Gdynia 2010.

BUDOWA SYMULATORA ODDYCHANIA WYKORZYSTYWANEGO DO BADAŃ ZGODNIE Z NORMĄ PN-EN 250:2014

STRESZCZENIE

W artykule omówiono podstawową budowę symulatora oddychania wykorzystywanego w Zakładzie Technologii Prac Podwodnych Akademii Marynarki Wojennej w Gdyni do badań powietrznych aparatów nurkowych o obiegu otwartym na zgodność z normą PN-EN 250:2014.

Słowa kluczowe:

powietrzny aparat nurkowy, hiperbaryczny symulator oddychania.